

# PISA STONE<sup>®</sup>

Classic Stone Bench | L:150cm

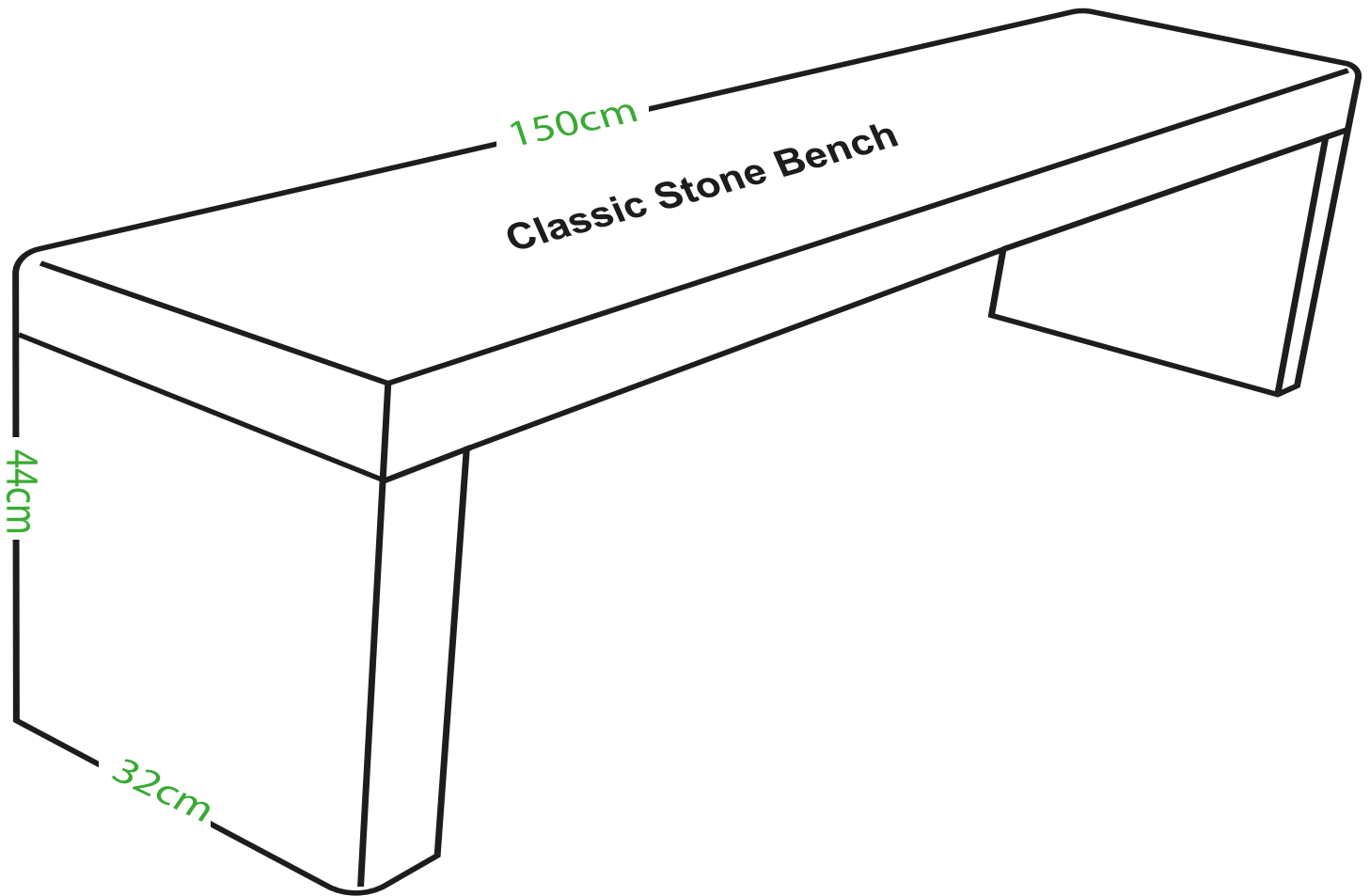

Product Type:

Classic Bench

Product Size:

L: 150cm - W: 32cm - H: 44cm

If you require a specific radius, size, or design variation, we offer a complete bespoke service. Our skilled stonemasons can tailor the bench to suit your exact project requirements.

 **MANCHESTER** (Manufacturer)

 **LONDON** (Showroom)

Visit Website



# PISA STONE<sup>®</sup>

Classic Stone Bench | L:130cm

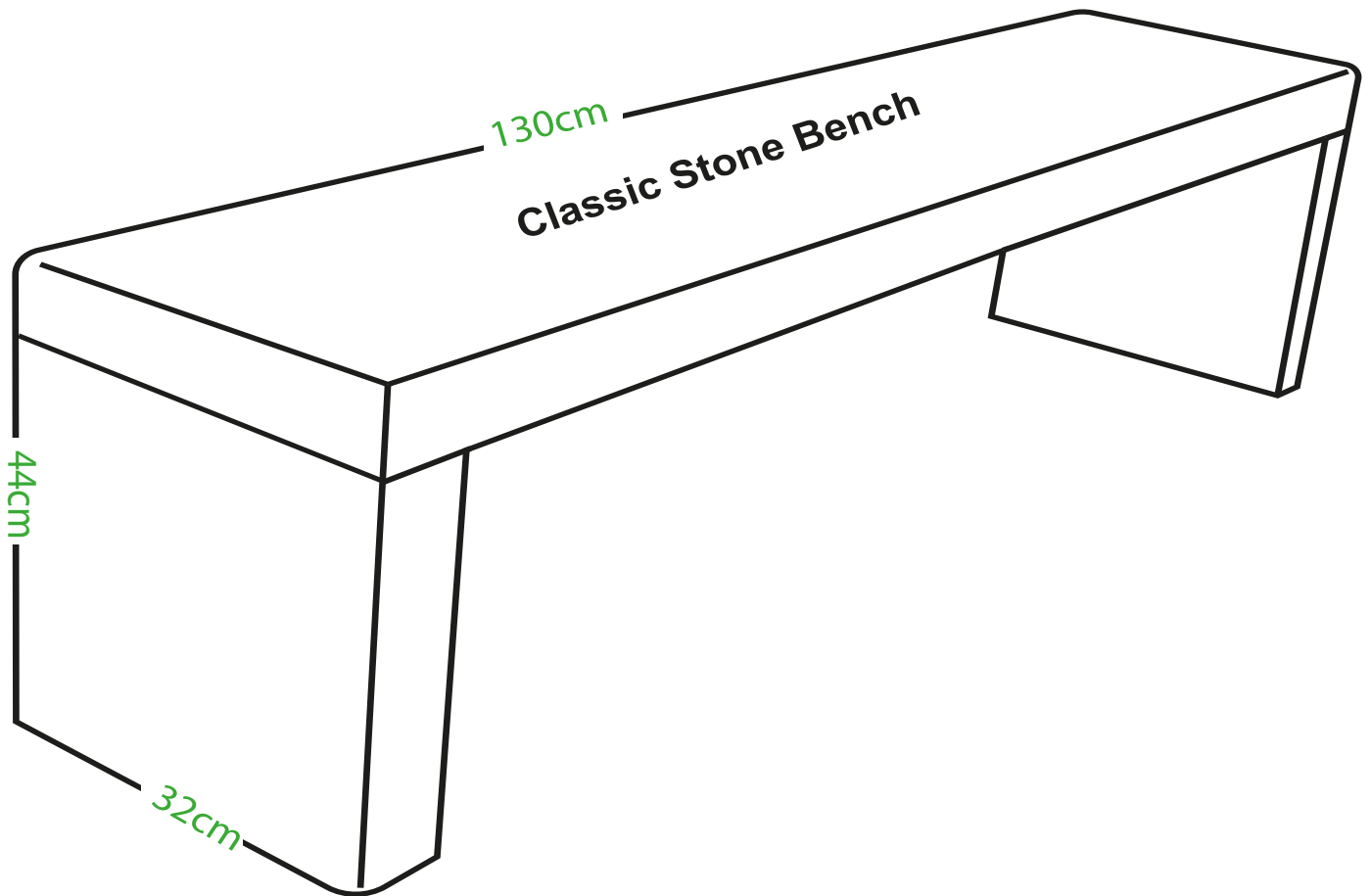

Product Type:

Classic Bench

Product Size:

L: 130cm - W: 32cm - H: 44cm

If you require a specific radius, size, or design variation, we offer a complete bespoke service. Our skilled stonemasons can tailor the bench to suit your exact project requirements.

 **MANCHESTER** (Manufacturer)

 **LONDON** (Showroom)

Visit Website



# PISA STONE<sup>®</sup>

Classic Stone Bench L:120cm

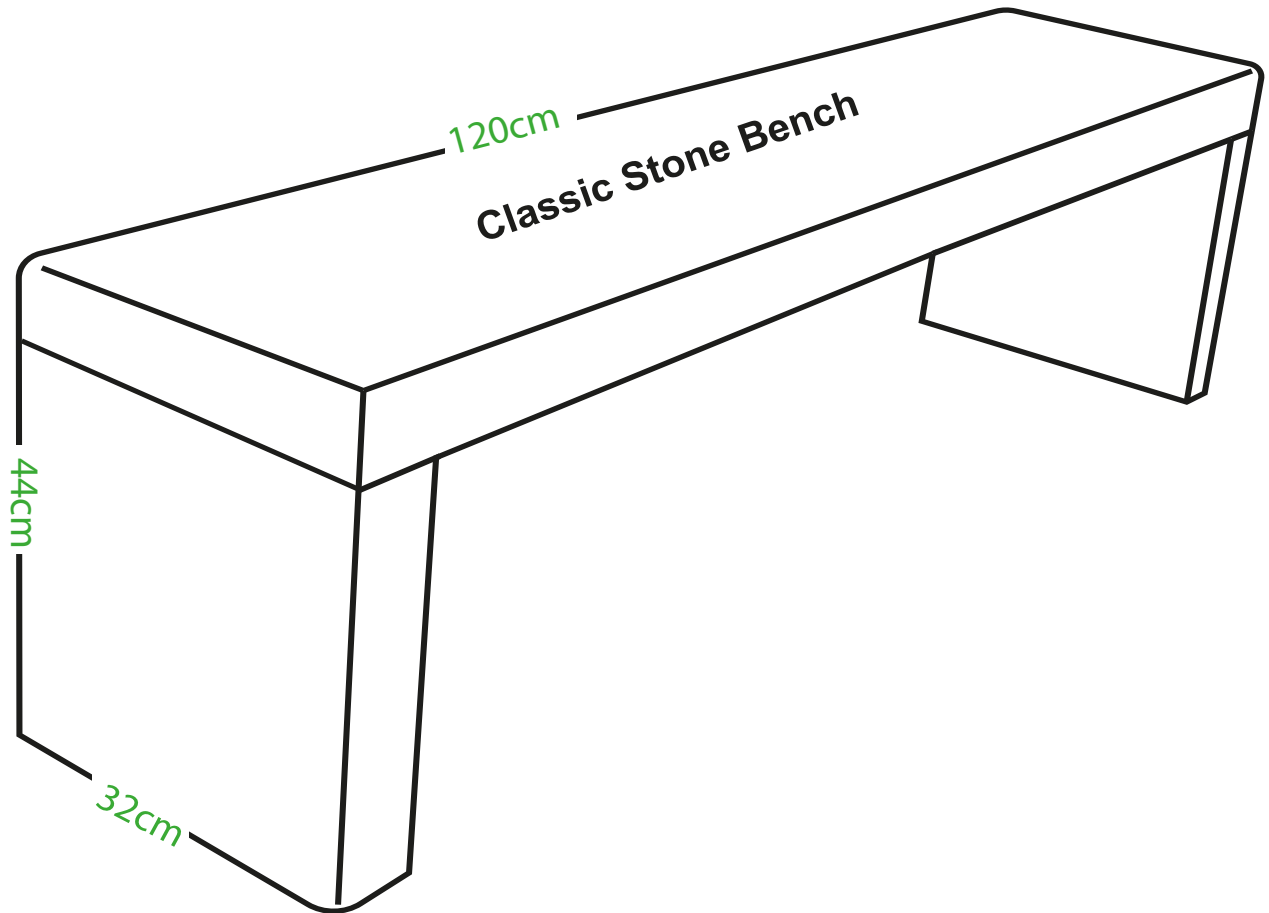

Product Type:

Classic Bench

Product Size:

L: 120cm - W: 32cm - H: 44cm

If you require a specific radius, size, or design variation, we offer a complete bespoke service. Our skilled stonemasons can tailor the bench to suit your exact project requirements.

 **MANCHESTER** (Manufacturer)

 **LONDON** (Showroom)

Visit Website



# PISA STONE<sup>®</sup>

Classic Stone Bench | L:100cm

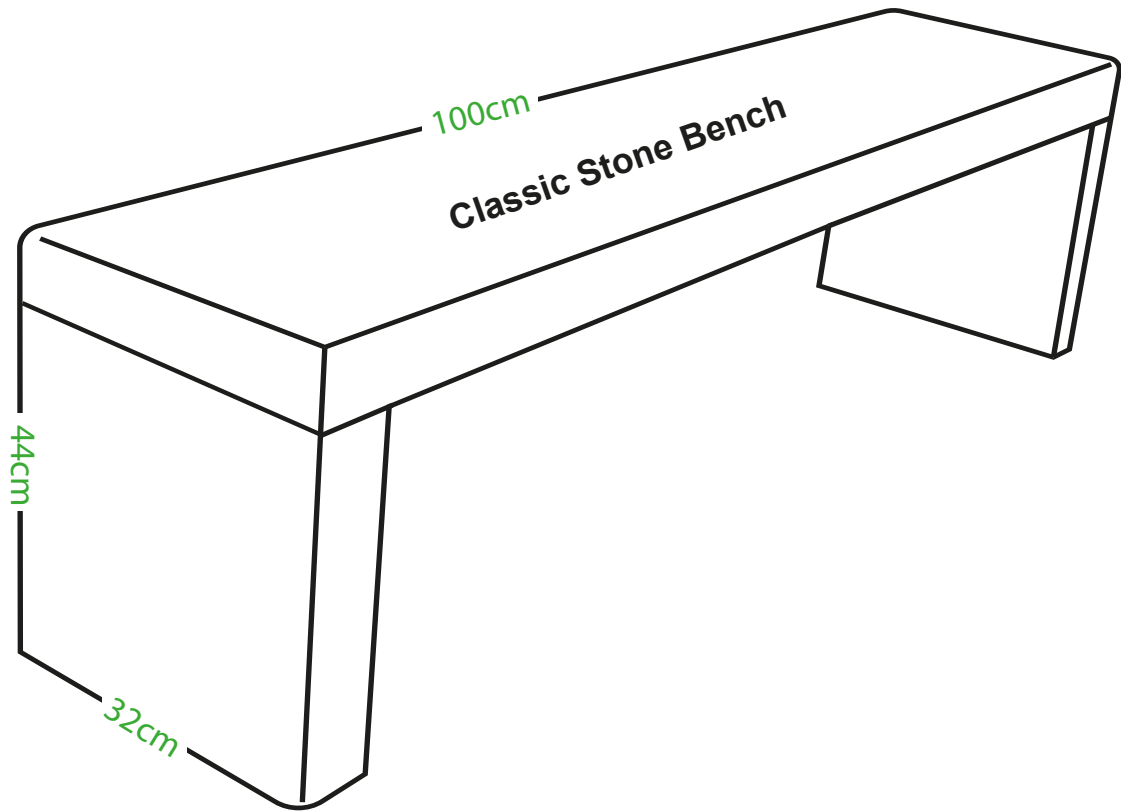

Product Type:

Classic Bench

Product Size:

L: 100cm - W: 32cm - H: 44cm

If you require a specific radius, size, or design variation, we offer a complete bespoke service. Our skilled stonemasons can tailor the bench to suit your exact project requirements.

 **MANCHESTER** (Manufacturer)

 **LONDON** (Showroom)

Visit Website



# PISA STONE<sup>®</sup>

## Classic Bench Assembly Guide

Setting up your stone bench is a straightforward process, but since stone is heavy and permanent, precision is key. Follow these steps for a secure and professional finish.

### Step:1

**Preparation:** Lay the bench top on a flat, level surface with the bottom side facing upward. To prevent scratching the polished surface, we recommend placing it on a piece of cardboard or a soft cloth.



Up-wards

Bench Bottom

### Step:2

**Alignment:** Position the legs to match the natural curvature of the bench. For optimal stability and aesthetics, we recommend placing the legs 0 mm in from each edge.

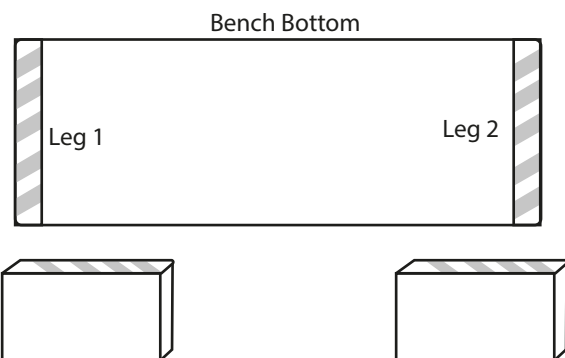
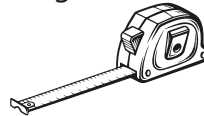

### Step:3

**Adhesion:** To secure the legs, apply a generous amount of CT1 adhesive (or a similar high-strength stone adhesive) to the designated areas on the underside of the bench top.

The adhesive is fully weather-resistant and can be applied outdoors. Allow the adhesive to cure undisturbed for 24 hours.

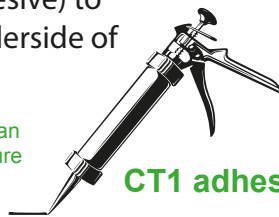

CT1 adhesive

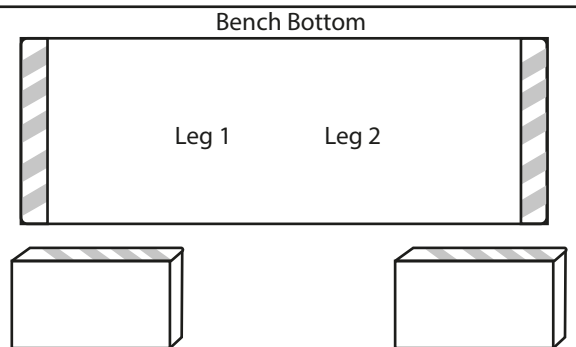

### Step:4

**Final Setup:** Once dry, carefully flip the bench over and move it into its final position.

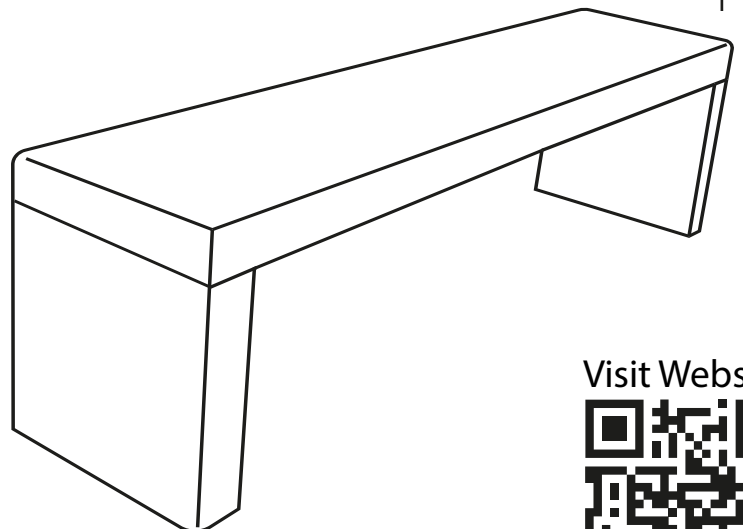

MANCHESTER (Manufacturer)



LONDON (Showroom)

Visit Website

