

PISA STONE[®]

Curved Stone Bench | L: 140cm

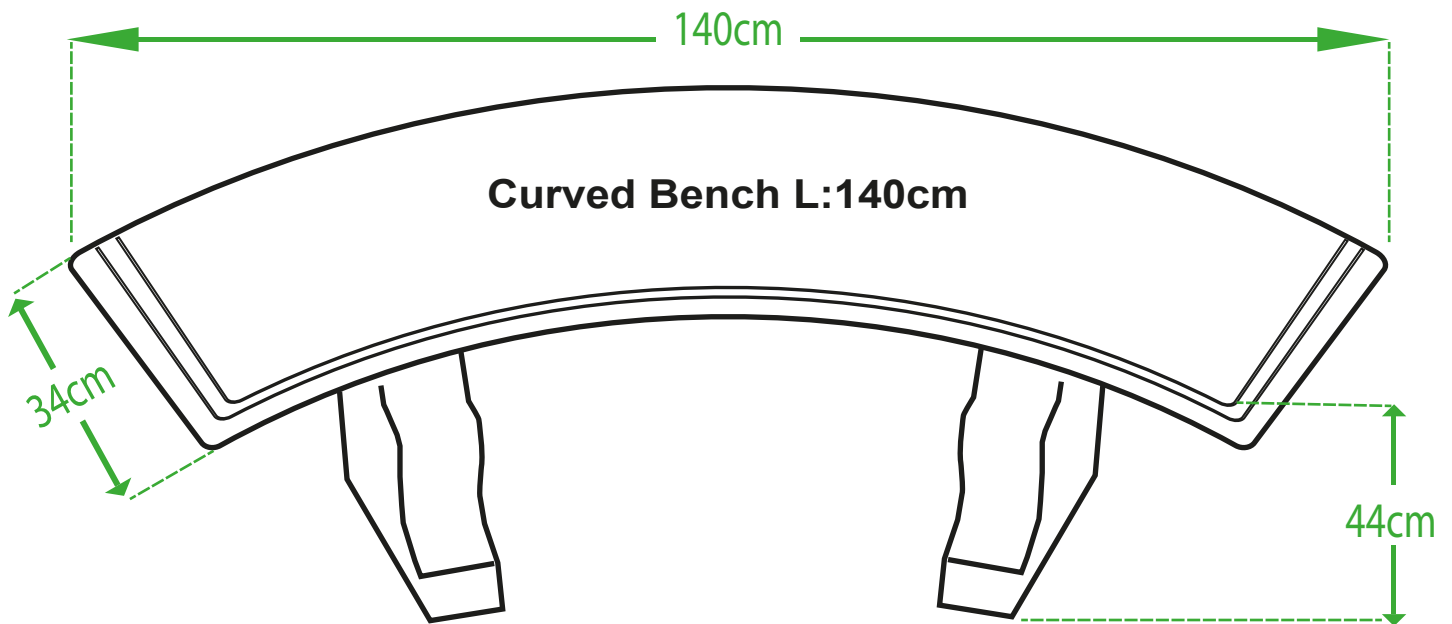

Product Type:

Curved Bench

Product Size:

L: 140cm - W: 34cm - H: 44cm

If you require a specific radius, size, or design variation, we offer a complete bespoke service. Our skilled stonemasons can tailor the bench to suit your exact project requirements.

 **MANCHESTER** (Manufacturer)

 **LONDON** (Showroom)

Visit Website



PISA STONE[®]

Curved Stone Bench | L: 120cm

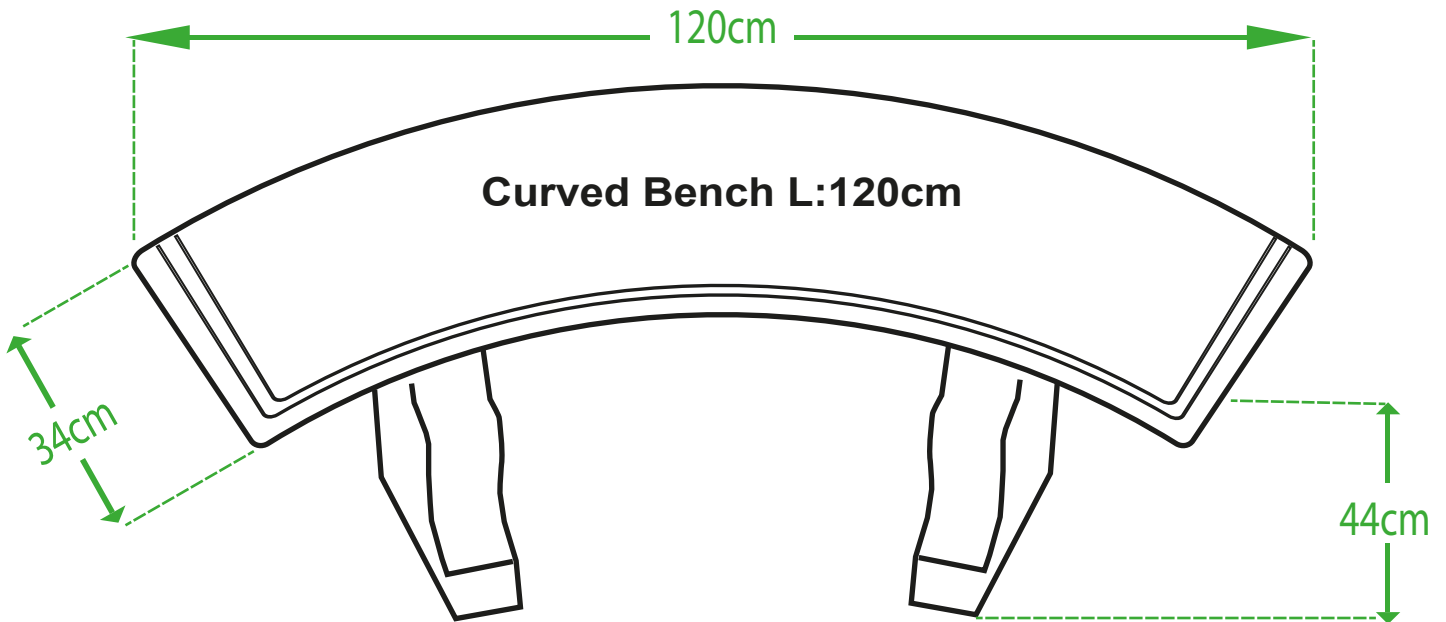

Product Type:

Curved Bench

Product Size:

L: 120cm - W: 34cm - H: 44cm

If you require a specific radius, size, or design variation, we offer a complete bespoke service. Our skilled stonemasons can tailor the bench to suit your exact project requirements.

 **MANCHESTER** (Manufacturer)

 **LONDON** (Showroom)

Visit Website



PISA STONE[®]

Curved Bench Assembly Guide

Setting up your stone bench is a straightforward process, but since stone is heavy and permanent, precision is key. Follow these steps for a secure and professional finish.

Step:1

Preparation: Lay the bench top on a flat, level surface with the bottom side facing upward. To prevent scratching the polished surface, we recommend placing it on a piece of cardboard or a soft cloth.

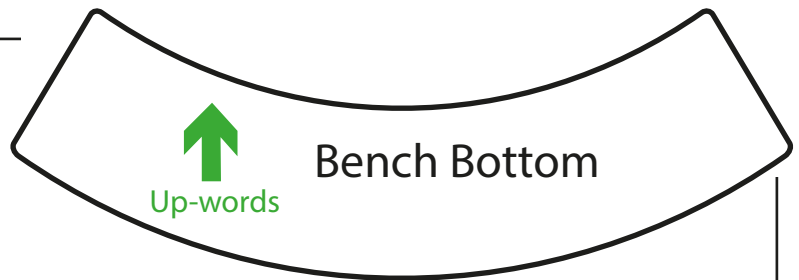

Step:2

Alignment: Position the legs to match the natural curvature of the bench. For optimal stability and aesthetics, we recommend placing the legs 150–300mm in from each edge.

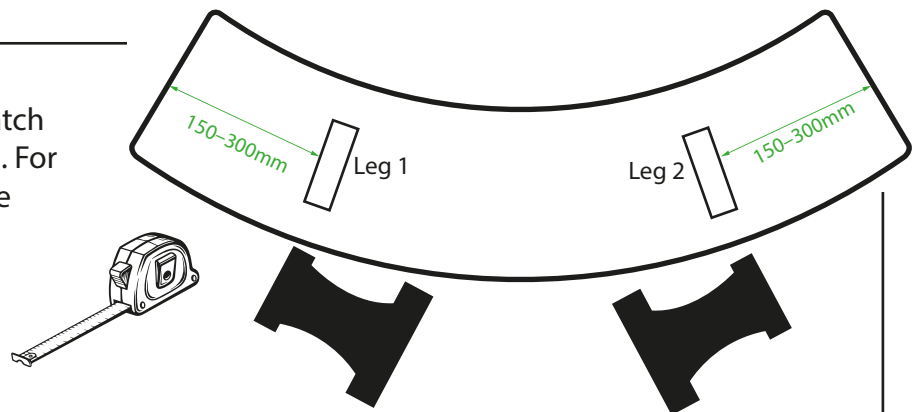

Step:3

Adhesion: To secure the legs, apply a generous amount of CT1 adhesive (or a similar high-strength stone adhesive) to the designated areas on the underside of the bench top.

The adhesive is fully weather-resistant and can be applied outdoors. Allow the adhesive to cure undisturbed for 24 hours.

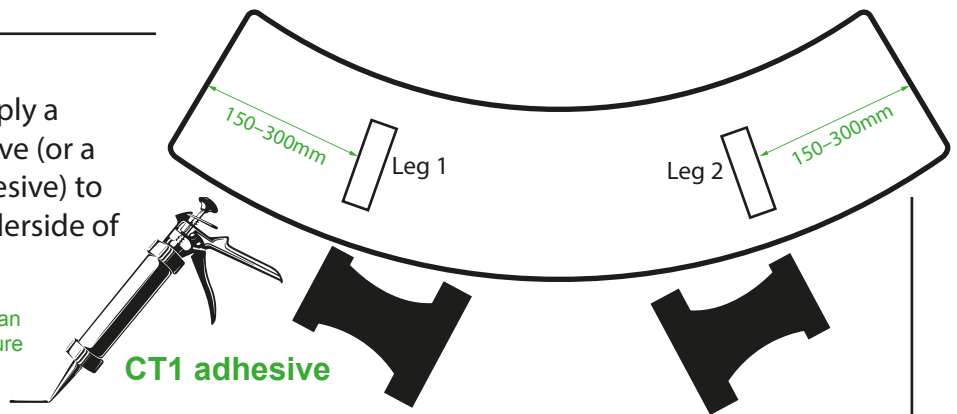

Step:4

Final Setup: Once dry, carefully flip the bench over and move it into its final position.

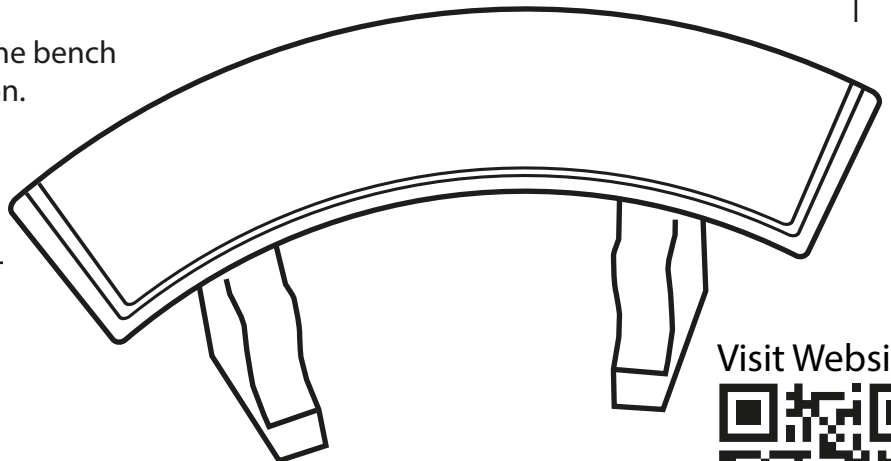

 **MANCHESTER** (Manufacturer)

 **LONDON** (Showroom)

Visit Website

